

Cuf

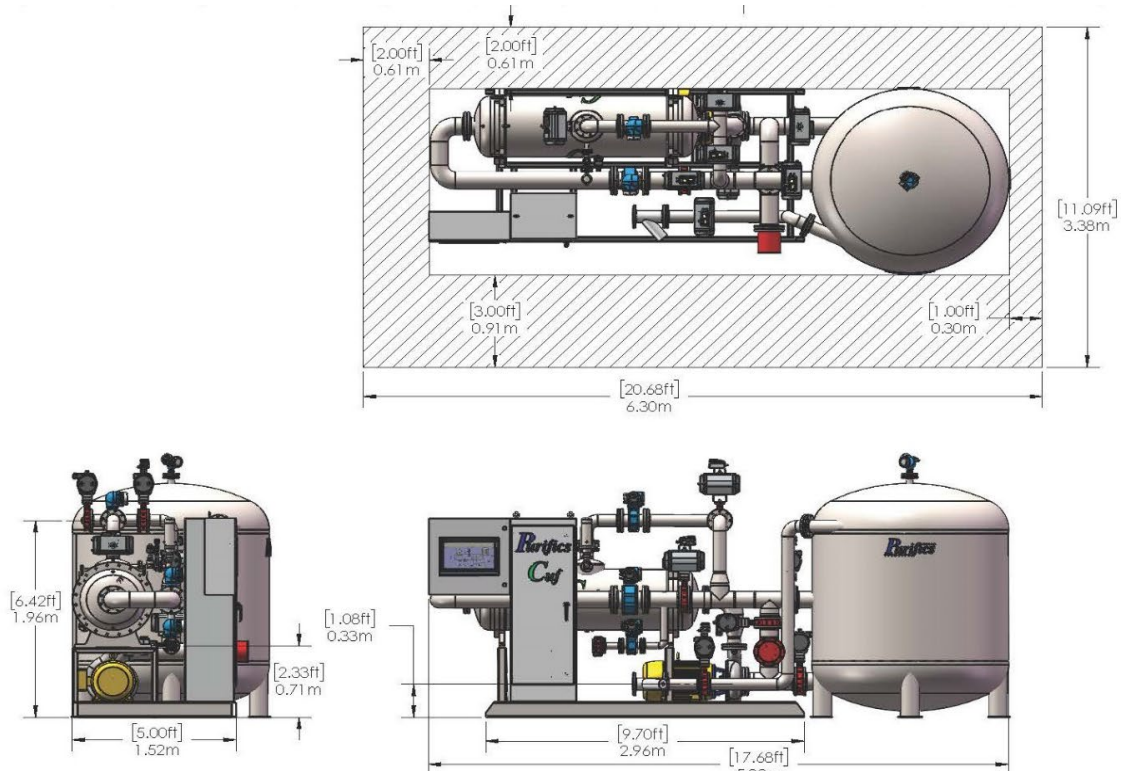

Typical Capacity	M = Single Module	DM = Dual Module
Ground Water	0.4 MGD / 1.6 MLD	0.8 MGD / 3.2 MLD
Surface & Waste Water	0.2 MGD / 0.8 MLD	0.4 MGD / 1.6 MLD

OPTIONS			
Drive Pumps	Primary & Residuals Disinfection	DO Addition – Metals Removal	Strainers / Screens
Inline pH Control	Level & Flow Control	Coagulant Feed – DOC Removal	Transfer & Blending
Inline Oxidation	Feed Pump	Camera	Direct & Indirect Integrity Test



TYPICAL SYSTEM DETAILS

Duty	>99%	Control	Fully Automated with Remote
Turndown	0-100% Automatic	Membrane Life	No End of Life
Filtrate Loss	0% ZLD	Wetted Material	Stainless Steel
Operating Modes	Continuous on Demand	UL Certified	NSF/ANSI 61
Filtration Modes	Pressurized or Gravity	Gasket Material	Viton or EPDM
Power	480 Volt, 60Hz 10 FLA and other	Electrical Codes	NFPA70, NFPA79 NFPA496, UL508A
Network	PROFINET	Inlet	Configurable #150 Flange
Instrument Air	Oil Free 120 PSI, 8 Bar	Outlet	Configurable #150 Flange
Weight Dry/Wet	2,200/3,300 LBS 1,000/1,500 KG	Concentrate Discharge	Configurable #150 Flange

Obtain equipment drawings for Application Engineering & Detailed Design.